

FROZEN  
BEVERAGE  
DISPENSERS



Unit Shown With  
Optional Base Cart



**LANCER. FBD 550**

**The 550 series is a fully automated frozen beverage dispenser series that provides the highest capacity and most consistent quality in the industry.**



**Unit shown with optional cart**

- Cart with casters allows for storage of syrup
- Bag-In-Box (BIB) syrup containers stack neatly in cabinet

- Attractive curved back-lit merchandiser graphic showcase standard**
- Side graphics are available

- Optimized refrigeration system**
- Electronic freeze control
  - Technologically advanced freeze cylinders
  - Patented liquid level control

- Compact size**
- Requires minimal counter or floor space

#### **DRAW PERFORMANCE**

**75 °F Ambient / 45% Relative Humidity**  
 Single Side: 1-46 oz./minute continuous  
 Alt. Sides: 1-64 oz./minute continuous

**90 °F Ambient / 65% Relative Humidity**  
 Single Side: 1-46 oz./minute continuous  
 Alt.: 1-46 oz./minute continuous





**Full louvered top and back panels**

- Provides superior air circulation for more efficient operation

**System control panel located behind hinged graphic panel**

- Easy access to multilevel service menu
- State of the art electronics
- Fully automated operation to minimize need for user input
- Daily programmable defrost capability to align with retailer's business peaks
- Programmable sleep and wake features minimize energy consumption
- Air filter (washable) removable from behind front door

**Stainless steel cabinet**

- Insulated for quiet operation

**Inlet fittings**

- Syrup, CO<sub>2</sub>, and water are accessible at rear of cabinet

**Drip tray and cup rest**

- Removable for cleaning without the use of tools: comes with optional drain fitting kit

## SPECIFICATIONS

### DIMENSIONS

Countertop unit  
 Width: 17 in (432 mm)  
 Depth: 32 3/8 in (822 mm)  
 Height: 34 in (864 mm)

Floor mount unit  
 Width: 17 in (432 mm)  
 Depth: 32 3/8 in (822 mm)  
 Height: 68 in (1727 mm)

**ELECTRICAL** 215 to 245VAC, single phase; 3 wire, 30 amp  
 Refrigeration Unit:  
 18,000 BTU, R-404A (60Hz)  
 20,000 BTU, R-404A (60Hz)

**AMPERAGE**  
 14-16 (run load amps)

**SPACE REQUIRED**  
 Sides: 2 in (51 mm)  
 Back: 2 in (51 mm) minimum  
 Top: 12 in (305 mm)

**WEIGHT**  
 Operating unit: 345 lb (163.3 kg)  
 Base cabinet: 80 lb (36.3 kg)

**SYRUP CONNECTION**  
 Bag-In-Box (BIB) or Figal (tanks)

**MOTORS**  
 Beater: (2) 1/6 HP  
 Fan: (1) 1/4 HP

**WATER**  
 Fresh water, 25 PSI minimum

**Warranty:** For warranty specifics by product, contact your Lancer Sales Representatives.



### 2 Barrel High Quality Dispenser

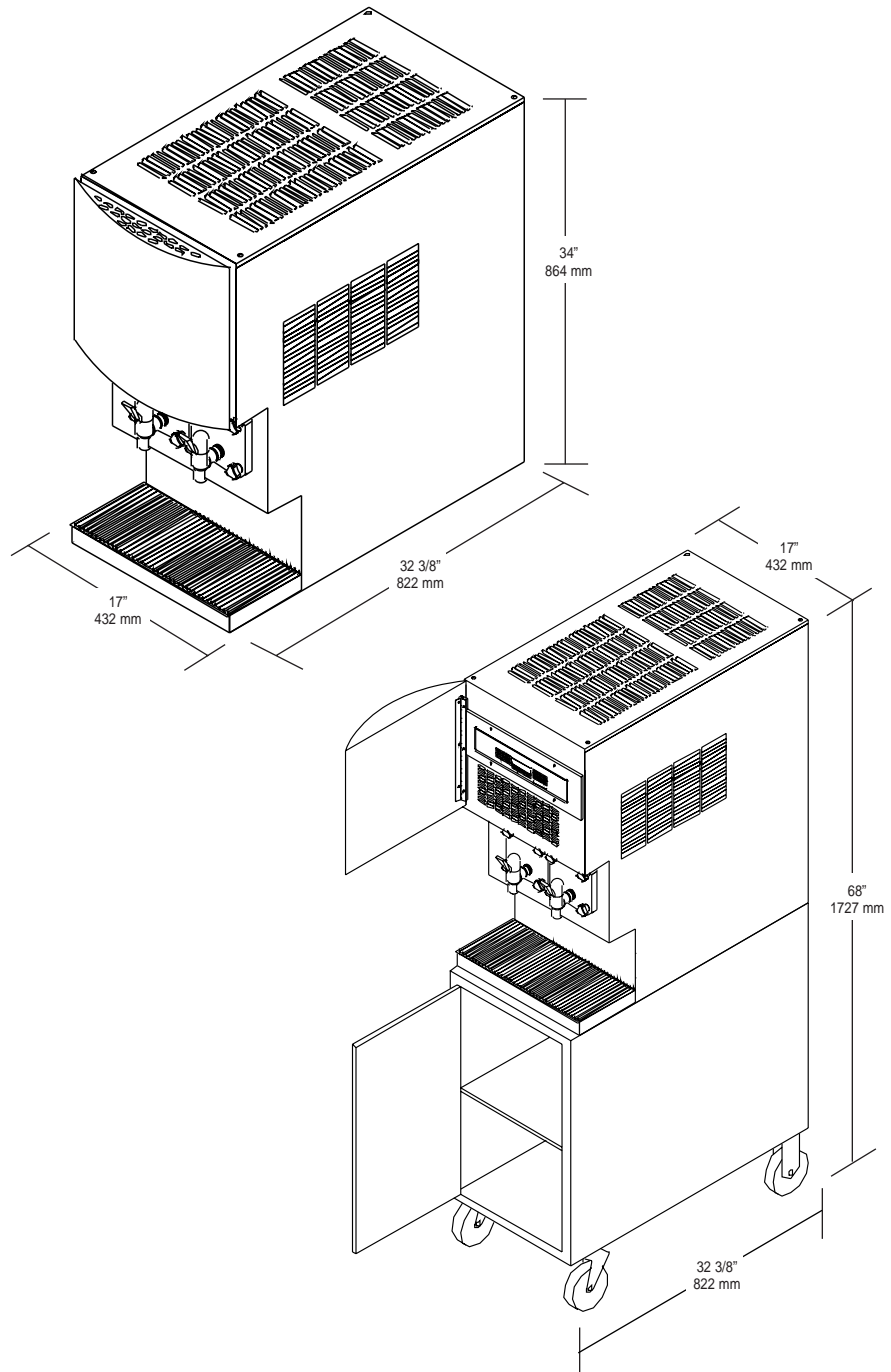

Equipment design and/or specifications may change without notice.

LANCER FBD 5620 Business Park Dr. • San Antonio, TX 78218 • 210-666-0544 • 1-866-989-2777 • FAX 210-666-2044 • www.lancercorp.com  
 Copyright—2003 by Lancer FBD, all rights reserved.