

LANCER



Optional Lighted Marquee Kit

Standard Performance Dispenser

CED 500-Juice

SPECIFICATIONS

DIMENSIONS

Width: 10.375 in (264 mm)
 Depth: 25.25 in (641 mm)
 Height: 27.5 in (699 mm)

ELECTRICAL

115V, 60Hz, 7.0 A
 UL grounded cord and plug

WEIGHT

Shipping: 108 lbs (49 kg)
 Counter, with water: 145 lbs (66 kg)
 Ice bank: 17 lbs

FITTINGS

Stainless steel, labeled inlet
 syrup and water: 3/8" barb

VALVES Flomatic

COMPRESSOR 1/4 Hp

MOTORS

Agitator 15 W
 Condenser fan 9 W

ICE BANK CONTROL

Lancer Electronic Ice Bank Control

TRANSFORMER 24VAC Secondary

Warranty: For warranty specifics by product,
 contact your Lancer Sales Representatives.



500—Standard Performance Juice Dispenser

- 1/4 Hp 17 lb ice bank, flooded manifold
- Occupies a small area of counter space, only 10 3/8" wide. Compare with conventional dispenser
- All valves can be serviced independently
- Insulation is CFC-free structural foam
- Stainless steel exterior, water bath, product lines and drip tray assembly
- Removable refrigeration deck. All installation from front of unit. Adaptable for Bag-In-Box or transfer tanks
- CFC-free R134A refrigerant
- Juice graphic decals and white bonnet are standard
- Leg kit included
- Optional lighted marquee kit

DRAW PERFORMANCE

Number of drinks below 40°F (4.5°C)

75°F (24°C) Ambient Temperature

2-12 oz/min:	98
4-12 oz/min:	40
Pull Down Time:	2:35
Recovery Time:	1:30

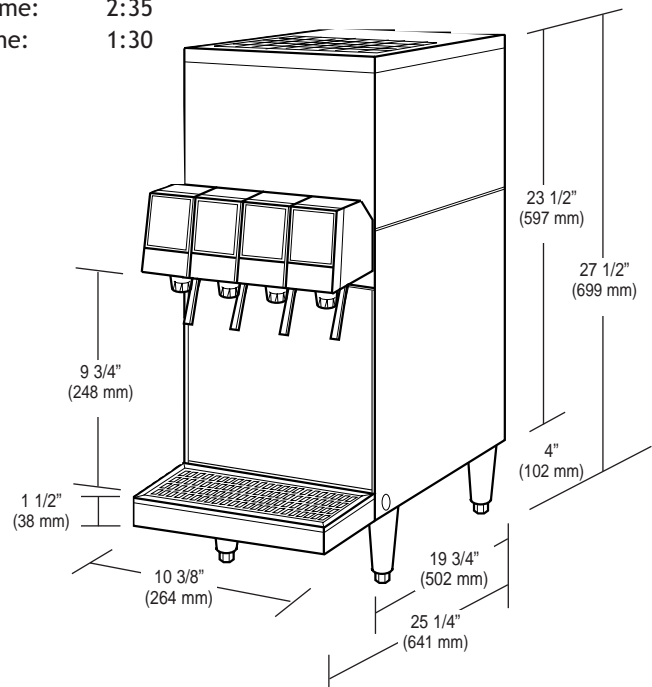

LANCER®

Equipment design and/or specifications may change without notice.

CORPORATE OFFICE 6655 Lancer Blvd • San Antonio, TX 78219 • 210-310-7000 • 1-800-729-1500 • FAX 210-310-7250 • www.lancercorp.com
 "Lancer" is the registered trademark of Lancer Corporation • Copyright—2003 by Lancer, all rights reserved.