

LANCER



Optional Lighted Marquee Kit

Standard Performance Dispenser

CED 1500-Juice

CED 1500-Juice

SPECIFICATIONS

DIMENSIONS

Width: 19 3/16 in (487 mm)
Depth: 24 in (610 mm)
Height: 25 3/8 in (645 mm)

ELECTRICAL

115V, 60Hz, 7.8 A
Optional 230V, 50Hz,
single phase, 4.4A

WEIGHT

Shipping: 150 lbs (68 kg)
Counter, with water:
261 lbs (118 kg)

FITTINGS

Stainless steel, labeled inlet
syrup and water: 3/8" barb

VALVES

Flomatic only

COMPRESSOR 1/3 Hp

MOTORS

Agitator 25 W
Condenser fan 9 W

ICE BANK CONTROL

Lancer Electronic Ice Bank Control

TRANSFORMER 24VAC Secondary

WATER BATH CAPACITY 13.1 gallons

Warranty: For warranty specifics by product,
contact your Lancer Sales Representatives.



1500—Standard Performance Chilled Juice Dispenser

- 1/3 Hp, 30 lb ice bank
- Ideal for medium to high volume accounts
- Stainless steel cabinet, product lines and splash plate
- Available with 5 or 6 dispensing valves. All valves can be serviced independently
- Adaptable for bag-in-box or transfer tanks
- Available with chilled syrup coils or unchilled syrup lines for high viscosity concentrates
- Insulation is CFC-free structural foam
- CFC-free R134A refrigerant
- Chilled Juice graphic decals and white bonnet are standard
- Optional lighted marquee kit and leg kit

DRAW PERFORMANCE

Number of drinks below 40°F (4.5°C)

75°F (24°C) Ambient Temperature

2-12 oz/min: 200

2-24 oz/min: 106

90°F (32°C) Ambient Temperature

4-12 oz/min: 110

2-24 oz/min: 55

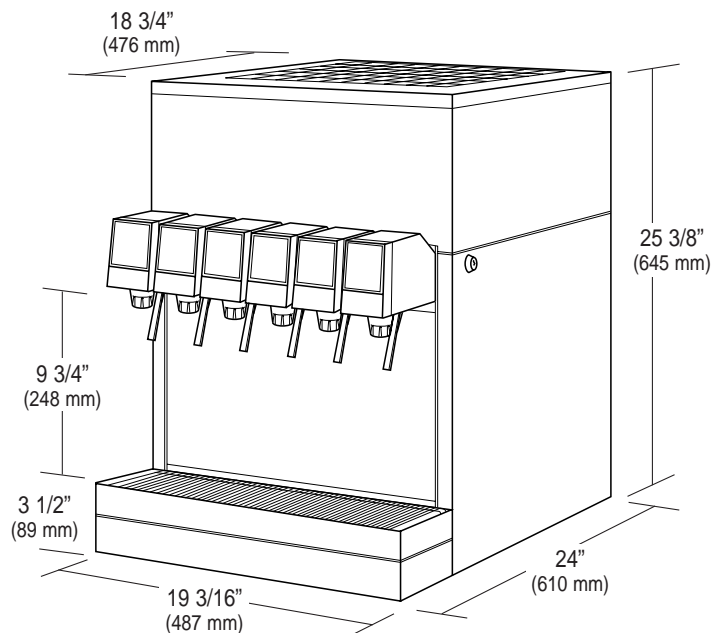

LANCER

Equipment design and/or specifications may change without notice.

CORPORATE OFFICE 6655 Lancer Blvd • San Antonio, TX 78219 • 210-310-7000 • 1-800-729-1500 • FAX 210-310-7250 • www.lancercorp.com
"Lancer" is the registered trademark of Lancer Corporation • Copyright—2003 by Lancer, all rights reserved.