

# LANCER



Optional Lighted Marquee

Standard Performance Dispenser

**CED 500**

## SPECIFICATIONS

### DIMENSIONS

Width: 10.375 in (264 mm)  
 Depth: 25.25 in (641 mm)  
 Height: 27.5 in (699 mm)

### ELECTRICAL

115V, 60Hz, 7 A  
 Optional 230V, 50Hz or  
 220V, 60Hz, 3.3 A  
 UL grounded cord and plug

### WEIGHT

Shipping: 108 lbs (49 kg)  
 Counter, with water: 145 lbs (66 kg)\  
 Ice bank: 17 lbs (8 kg)

### FITTINGS

Stainless steel, labeled inlet  
 Syrup and water: 3/8" barb

COMPRESSOR 1/4 hp

### MOTORS

Agitator: 15 W  
 Condenser fan: 9 W

### ICE BANK CONTROL

Lancer Electronic Ice Bank Control

TRANSFORMER 24 VAC Secondary

WATER BATH CAPACITY 5 gallons

Warranty: For warranty specifics by product,  
 contact your Lancer Sales Representatives.



### 500—Standard Performance

- 1/4 hp, 17 lb ice bank, flooded manifold
- Stainless steel cabinet, water bath, product lines and drip tray assembly
- Occupies a small area of counter space, only 10 3/8" wide. Compare with conventional dispenser
- Available with 4 post-mix dispensing valves
- All valves can be serviced independently
- Insulation is CFC-free structural foam
- Removable refrigeration deck. All installation from front of unit.
- Leg kit included
- CFC-free, R134A Refrigerant
- Optional lighted front marquee kit

### DRAW PERFORMANCE

Number of Drinks Below 40°F (4.5°C)

75°F (24°C) Ambient Temperature

2-12 oz/min:	161
4-12 oz/min:	47
Pull Down Time:	2:35
Recovery Time:	1:30

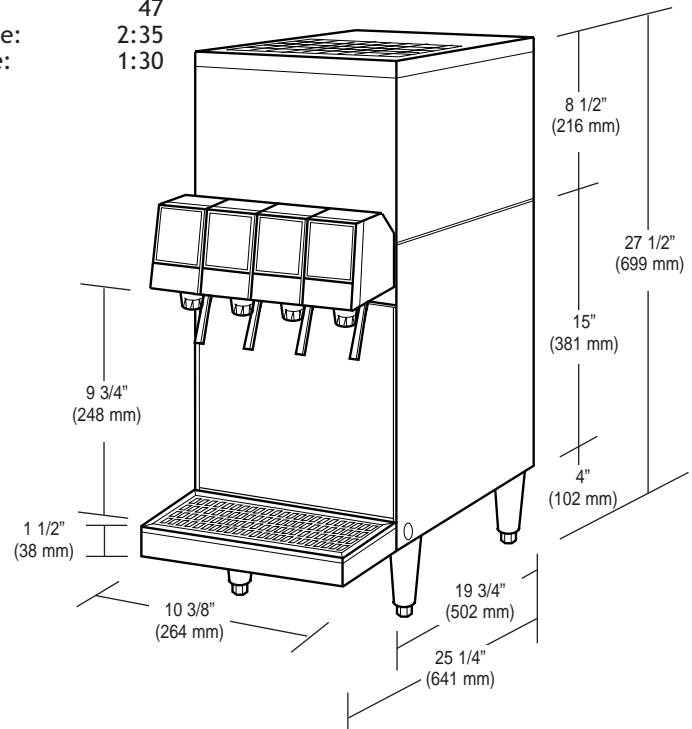

# LANCER®

Equipment design and/or specifications may change without notice.

CORPORATE OFFICE 6655 Lancer Blvd • San Antonio, TX 78219 • 210-310-7000 • 1-800-729-1500 • FAX 210-310-7250 • www.lancercorp.com  
 "Lancer" is the registered trademark of Lancer Corporation • Copyright—2003 by Lancer, all rights reserved. "Coca-Cola" is a registered trademark of The Coca-Cola Company

38-0500 03/03