

BRAND MERCHANDISING AND ID

ICE COMBO DISPENSER

- 44" wide, 12 LEV®, lever or push button
- Low ice sensing is standard with visual indicator; additional ice level sensors makes unit compatible with ice link systems
- Ice capacity of 360 lbs (163 kg) with dispensable ice 300 lbs (136 kg)
- Coca-Cola side and back graphics
- Illuminated interchangeable front graphics
- On-site choice of lever or push ice dispensing
- 12 valve
3-2-1-1-2-3 flex manifold configurations

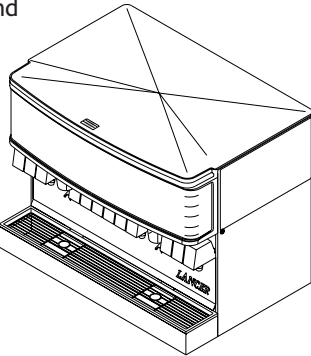

ICE MAKER COMPATIBILITY

- Accepts 30" wide ice makers with adaptor
- Manual front load capability when ice maker installed
- Variable automatic agitation timer
- Stainless steel wrapper
- Stainless steel inner liner
- Large capacity drip tray

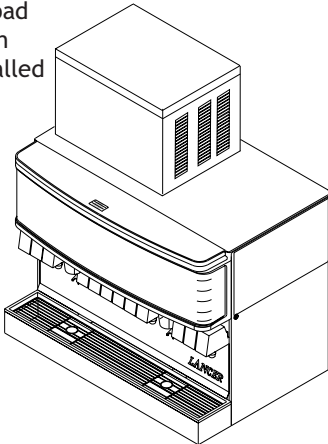

Ice Dispensing

- Dual dispensing points
- Ice maker compatibility
- Manual ice fill capability

Illuminated interchangeable graphics

- Standard - fluorescent, 15 watt light bulbs

44" wide (12 valve)

Push or Lever ice dispensing versatility

- Multiple non-carbonated drink capabilities

Large capacity drip tray



DRAW PERFORMANCE

Number of Drinks Below 40°F

75°F (24°C) Ambient Temperature

12 oz./20 drinks per minute
24 oz./8 drinks per minute

90°F (32°C) Ambient Temperature

12 oz./14 drinks per minute
24 oz./5 drinks per minute

Units can supply drinks under 40°F at rated draw performance continuously as long as ice is kept on cold plate.



**Resettable Transformers
Solid State Control**

- Controls low ice sensing
- Diagnostic LED
- Customer control of auto agitation
- Front serviceability

Insulation

1 1/4" CFC - free insulation

Standard valve key lock

Low ice sensing is standard with visual indicator

- Adjustable ice dispense rate
- Smooth and even ice dispensing flow
- 360 lbs ice capacity, 300 lbs dispensable
- Ice link compatible

Stainless steel construction

- Stainless steel bin liner

Removable wrapper

Front Serviceability

- Connection of syrup and soda lines

SPECIFICATIONS

DIMENSIONS

Width: 44 in (1118 mm)
 Depth: 30.5 in (775 mm)
 Height: 34 in (864 mm)

ELECTRICAL 115V electrical system
 (230V 50/60Hz available)

SPACE REQUIRED 44 in x 30.5 in
 (1118 mm x 775 mm)

WEIGHT

Shipping: Approximately
 460 lbs (209 kg)
 Counter, with ice: 820 lbs (372 kg)

ICE

Dispensing: 300 lbs (136 kg)
 Capacity: 360 lbs (163 kg)

FITTINGS

Syrup and soda inlet: 3/8" male barb

KEY LOCK SWITCH

VALVES LEV® 3.0 LEV® and 4.5 LEV®
 other valves available upon request

FLEX MANIFOLD CONFIGURATIONS

3-2-1-1-2-3

Warranty: For warranty specifics by product,
 contact your Lancer Sales Representatives.



12 valve—44" wide Coca-Cola dispenser

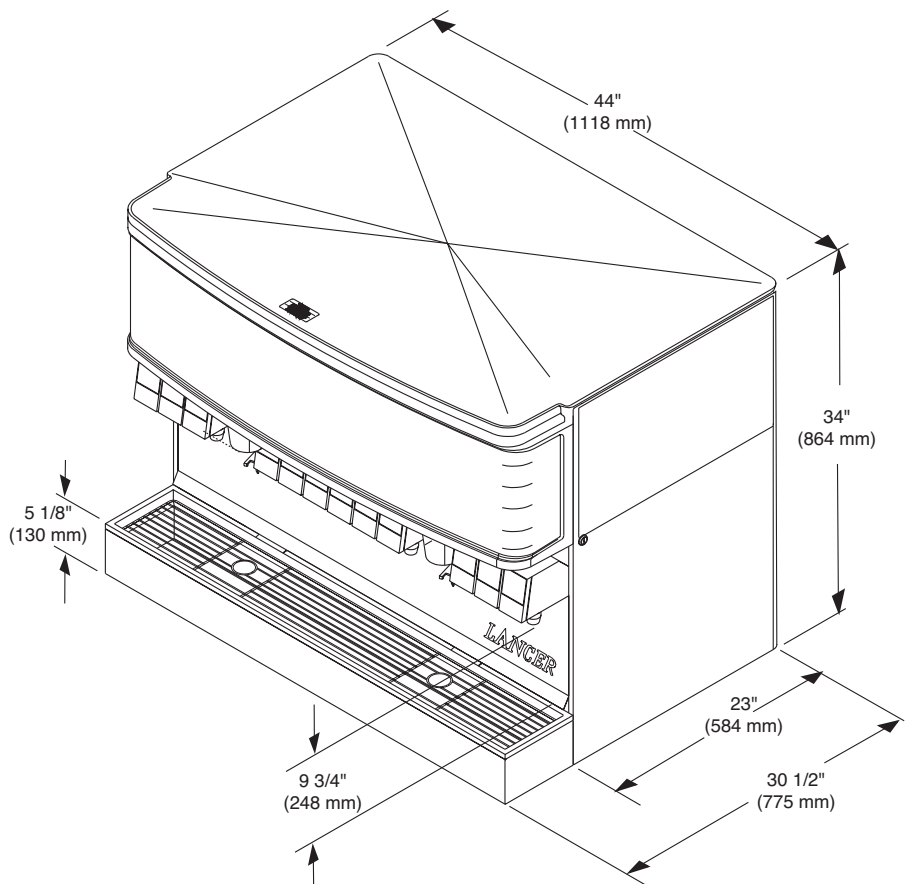

LANCER®