

# LANCER®



12 Valve—44” Wide Dispenser

**IBD 4500**

## DISPENSER VERSATILITY

### ICE COMBO DISPENSER

- 44" wide, 12 valve
- Low ice sensing is standard with visual indicator
- Ice capacity of 360 lbs (163 kg) with 300 lbs (136 kg) dispensable
- Illuminated interchangeable front graphics
- On-site choice of lever or push ice dispensing
- 12 valve 3-2-1-1-2-3 flex manifold configurations

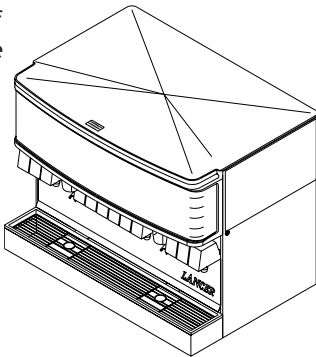

### ICE MAKER COMPATIBILITY

- Accepts 30" wide ice makers with adapter
- Manual front load capability when ice maker installed
- Variable automatic agitation timer
- Stainless steel wrapper
- Stainless steel inner liner
- Large capacity drip tray

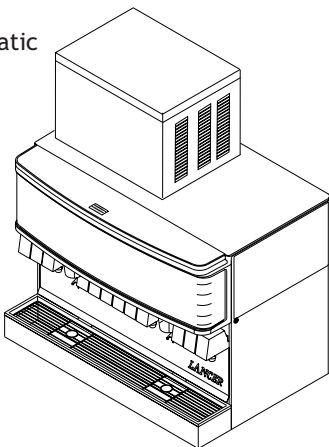

### Ice Dispensing

- Dual dispensing points
- Ice maker compatibility
- Manual ice fill capability

### Illuminated interchangeable graphics

- Standard - fluorescent, 15 watt light bulbs

### 44" wide (12 valve)

### Push or Lever ice dispensing versatility

- Multiple non-carbonated drink capabilities

### Large capacity drip tray



### DRAW PERFORMANCE

#### Number of Drinks Below 40°F

#### 75°F (24°C) Ambient Temperature

12 oz./20 drinks per minute  
24 oz./8 drinks per minute

#### 90°F (32°C) Ambient Temperature

12 oz./14 drinks per minute  
24 oz./5 drinks per minute

*Units can supply drinks under 40°F at rated draw performance continuously as long as ice is kept on cold plate.*



**Resettable Transformers  
Solid State Control**

- Controls low ice sensing
- Diagnostic LED
- Customer control of auto agitation
- Front serviceability

**Insulation**

1 1/4" CFC - free insulation

**Standard valve key lock**

**Low ice sensing is standard with visual indicator**

- Adjustable ice dispense rate
- Smooth and even ice dispensing flow
- 360 lbs ice capacity, 300 lbs dispensable
- Ice link compatible

**Stainless steel construction**

- Stainless steel bin liner

**Removable wrapper**

**Front Serviceability**

- Connection of syrup and soda lines

## SPECIFICATIONS

### DIMENSIONS

Width: 44 in (1118 mm)  
Depth: 30.5 in (775 mm)  
Height: 34 in (864 mm)

**ELECTRICAL** 115V electrical system  
(230V 50/60Hz available)

**SPACE REQUIRED** 44 in x 30.5 in  
(1118 mm x 775 mm)

### WEIGHT

Shipping: Approximately  
460 lbs (209 kg)  
Counter, with ice: 820 lbs (372 kg)

### ICE

Dispensing: 300 lbs (136 kg)  
Capacity: 360 lbs (163 kg)

### FITTINGS

Syrup and soda inlet: 3/8" male barb

### KEY LOCK SWITCH

### VALVES

Flomatic

### FLEX MANIFOLD CONFIGURATIONS

3-2-1-1-2-3

**Warranty:** For warranty specifics by product,  
contact your Lancer Sales Representatives.



### 12 valve—44" wide Chill-Out dispenser

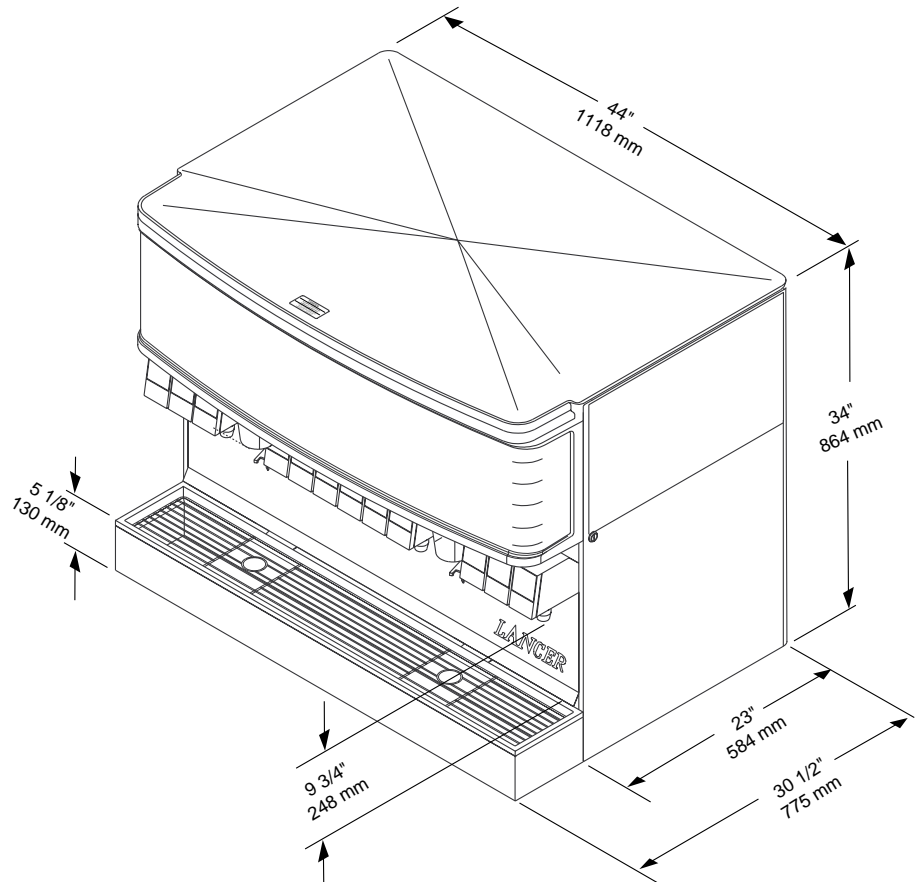

# LANCER®

Equipment design and/or specifications may change without notice.

**CORPORATE OFFICE** 6655 Lancer Blvd • San Antonio, TX 78219 • 210-310-7000 • 1-800-729-1500 • FAX 210-310-7250 • www.lancercorp.com  
"Lancer" is the registered trademark of Lancer Corporation • Copyright—2003 by Lancer, all rights reserved.