

LANCER®



8 Valve—30” Wide Dispenser

IBD 4500

DISPENSER VERSATILITY

ICE COMBO DISPENSER

- 30" wide, 8 or 10 valves
- Low ice sensing is standard with visual indicator
- Ice Capacity of 250 lbs (113) kg with dispensable 220 lbs (100 kg)
- Illuminated interchangeable front graphics
- On-site choice of lever or push ice dispensing
- 8 valve 3-1-1-3 flex manifold configuration
10 valve 3-1-2-1-3 flex manifold configuration
- Hard plumbed syrup and water lines

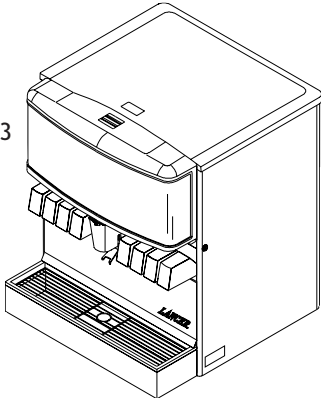

ICE MAKER COMPATIBILITY

- Accepts 30" wide ice makers
- Accepts 22" wide ice makers with adapter
- Variable automatic agitation timer
- Stainless steel wrapper
- Stainless steel inner liner
- Large capacity drip tray
- Manual front load when ice maker installed

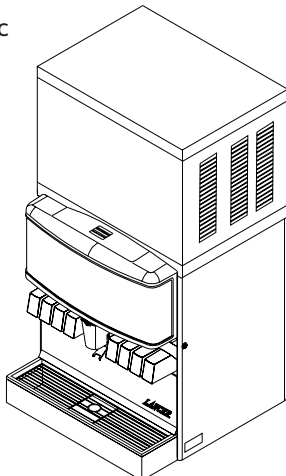

Ice Dispensing

- Ice maker compatibility
- Manual ice fill capability

Illuminated interchangeable graphics

- Standard - fluorescent, 15 watt light blub

Low ice sensing is standard with visual indicator

- Adjustable ice dispense rate
 - Smooth and even ice dispensing flow
- 250 lbs ice capacity with 220 lbs dispensable
 - Ice link compatible

30" wide (8 or 10 valve)

Push or Lever ice dispensing versatility

- Multiple non-carbonated drink capabilities

Front Serviceability

- Hard plumbed syrup and water lines
 - Drive shaft motor accessible

DRAW PERFORMANCE

Number of drinks below 40°F

75°F (24°C) Ambient Temperature

12 oz./14 drinks per minute

24 oz./6 drinks per minute

90°F (32°C) Ambient Temperature

12 oz./10 drinks per minute

24 oz./4 drinks per minute

Units can supply drinks under 40°F at rated draw performance continuously as long as ice is kept on cold plate.





**Resettable Transformers
Solid State Control**

- Controls low ice sensing
- Diagnostic LED
- Customer control of auto agitation
- Front serviceability

Standard valve key lock

Insulation
1 1/4" CFC - free insulation

Stainless steel construction
• Stainless steel bin liner

Removable wrapper

Large capacity drip tray

SPECIFICATIONS

DIMENSIONS

Width: 30 in (762 mm)
Depth: 30.5 in (775 mm)
Height: 34 in (864 mm)

ELECTRICAL 115V electrical system
(230V 50/60Hz available)

SPACE REQUIRED 30.5 in x 30.5 in
(775 mm x 775 mm)

WEIGHT

Shipping: Approximately
305 lbs (138 kg)
Counter, with ice:
645 lbs (293 kg)

ICE

Dispensing: 220 lbs (100 kg)
Capacity: 250 lbs (113 kg)

FITTINGS

Syrup and soda inlets:
3/8" male barb

KEY LOCK SWITCH

VALVES

Flomatic

FLEX MANIFOLD CONFIGURATIONS

8 Valve 3-1-1-3
10 Valve 3-1-2-1-3

Warranty: For warranty specifics by product,
contact your Lancer Sales Representatives.



8 valve—30" wide Chill-Out dispenser

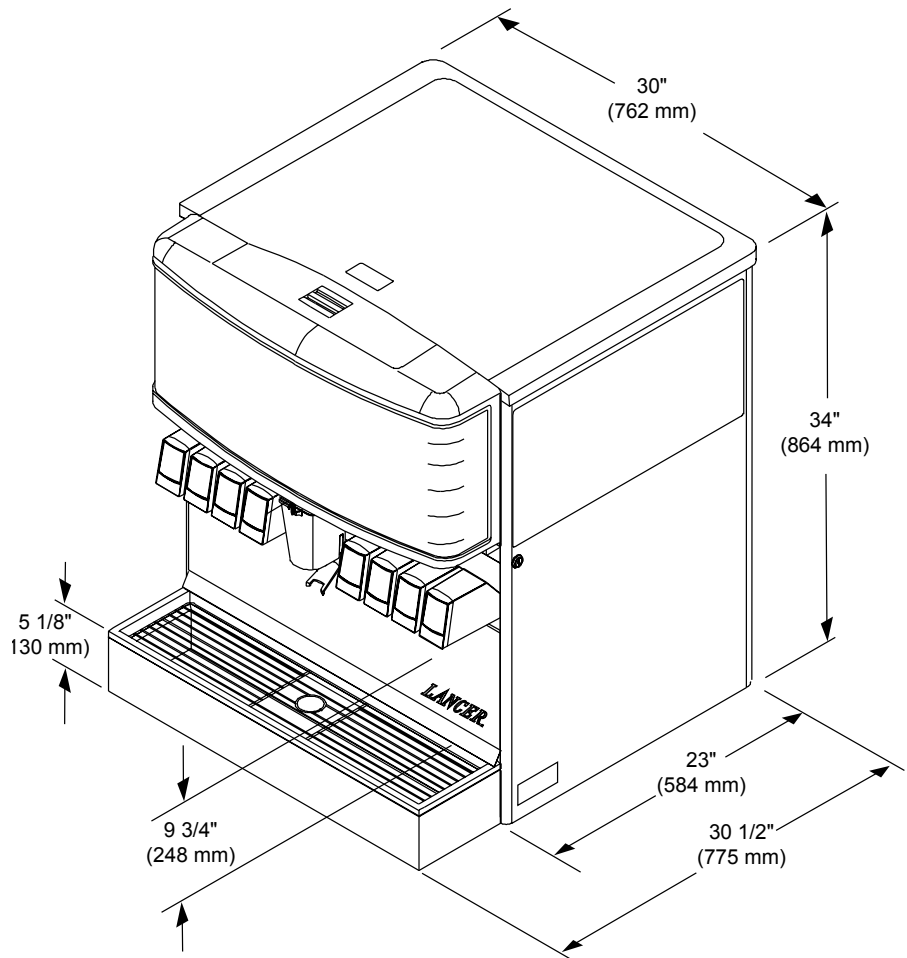

LANCER®

Equipment design and/or specifications may change without notice.

CORPORATE OFFICE 6655 Lancer Blvd • San Antonio, TX 78219 • 210-310-7000 • 1-800-729-1500 • FAX 210-310-7250 • www.lancercorp.com
"Lancer" is the registered trademark of Lancer Corporation • Copyright—2003 by Lancer, all rights reserved.